

FRONTLINE

Max. printing speed	60,000 copies per hour
Max. reel diameter	1150 mm
Max. web width	915 mm (36 inches)
Printing unit modules	H units
Cut off length	533, 546, 560, 578 mm (21, 21 1/2, 22, 22 3/4 inches)
Plate mounting	Toolless slot mounting
Reel splicer	Standalone auto reel splicer
Jaw folder (2:3:2)	48-page broadsheet / 96-page tabloid
Data management	PLC based
Optionals	Third (quarter) fold Parallel fold Turner bar Bay window Balloon former

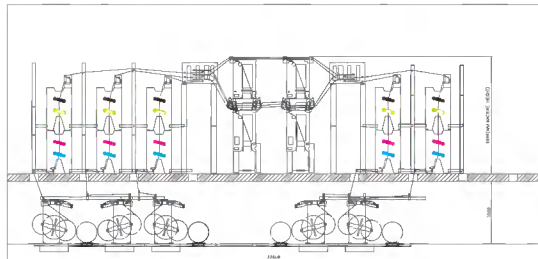
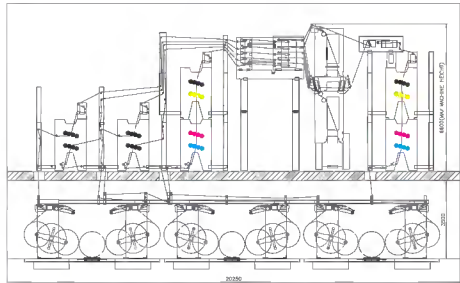

FRONTLINE

4-page web offset press



Manugraph India Ltd.

Sidhwa House, N.A. Sawant Marg, Colaba, Mumbai - 400 005, India. Phone: 91-22-2287 4815/4788/1191/0620.
Fax: +91 22 2287 0702 Email: sales@manugraph.com Website: www.manugraph.com

FRONTLINE is subject to continuous upgradation resulting from ongoing research and development and practical experiences gained. Therefore, in the interest of the customers we reserve the right to modify the specifications, features and technical data without notice. Only the specifications while confirming the order shall be binding.
FRONTLINE is a registered trademark of Manugraph India Ltd.



Inside

4 Areas of application
An efficient, productive press for today's requirements



5 Features
Know your FRONTLINE

6 Printing Units
Rugged Construction, Modular designs

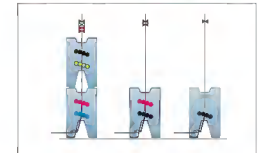

7 Selecting your FRONTLINE
A world of possibilities

8, 9 Choose the right configuration for the job
A wide range of production variants



10 Performance
Plate & blanket cylinders
Three-race roller bearings

11 Drive system
Shaftless technology



12, 13 Inking & Dampening systems
ManuColor Remote Inking System
Contactless dampening units

14, 15 Folder : Robust, Flexible
More product versatility



16 Web tension
Manugraph's web control system

17 Reel splicer : Solid, Reliable

18, 19 Total press control
Central console & PLC
Electricals

20 Specifications



FRONTLINE : An efficient, productive press for today's requirements

Productivity is the keynote behind the concept of FRONTLINE. Based on modular designs, FRONTLINE is an economic model that meets the printing requirements of high circulation newspapers efficiently. With a maximum output of 60,000 copies per hour and an excellent price performance ratio, FRONTLINE is a leader among single width, single circumference machines. The guaranteed performance of FRONTLINE, its short make ready and changeover times, flexibility and the right level of automation translate to high levels of productivity, most cost effectively.

FRONTLINE is operator friendly and easy to maintain - the two most important factors for economic and efficient production.

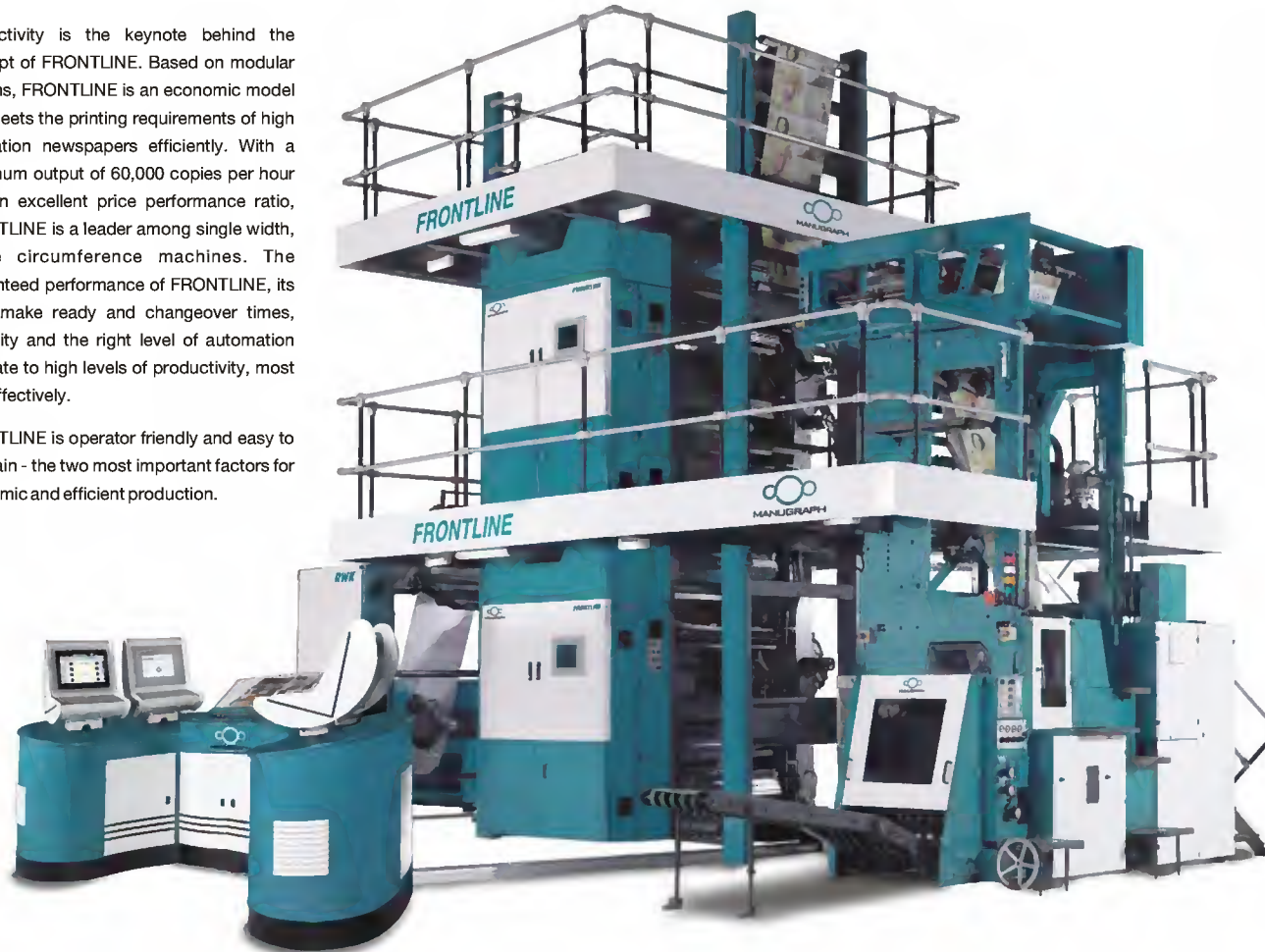

FRONTLINE : Features at a glance

- ❑ 60,000 c.p.h. :- Max. printing speed
- ❑ Vertical web leads
- ❑ Flat cylinder arrangement
- ❑ Reel splicers with precise tension control system
- ❑ Toolless plate lock up
- ❑ Pneumatics for impression and inking/dampening
- ❑ Motorized bustle wheel for fan out control
- ❑ Three-race bearings for main printing cylinders
- ❑ Three Roller Spray-dampening system
- ❑ 9-roller inking system with two Forme rollers of different diameters
- ❑ Auto tracking of ink duct roller and spray dampening
- ❑ 2:3:2 jaw folder
- ❑ PLC-controlled operation
- ❑ Shaftless drive system
- ❑ Wide range of 3rd party auxiliaries for increased productivity, such as ink pumps, centralized chilling and dampening systems
- ❑ CIP3 compatibility for ink key presetting
- ❑ Automatic color registration, cut-off control system
- ❑ Remote ink control system

Printing Units : Rugged Construction, Modular Designs

The units are of rugged construction with box type sidewalls on drive side and plain sidewall on operating side, made from high strength cast iron. The space saving design of FRONTLINE and the high quality components that go into its manufacturing are the hallmarks of the machine.

Printing units are available in flat cylinder arrangement with vertical web lead. The 4-high tower comprises 2 H units placed one over the other. These offer high color and page capacities predominantly for newspapers. PLC based electrical controls simplify operation and increase reliability.

FRONTLINE incorporates precisely manufactured gears, special purpose three race play-free bearings for cylinders and technologies that guarantee constant web tension and perfect registration at top speed. Such features, complimented by short web leads, and belt type web threading system from splicer to top of tower ensure quick start-up. Also there are Web catchers at entry and exit of each web.

Safety features are as per CE norms.

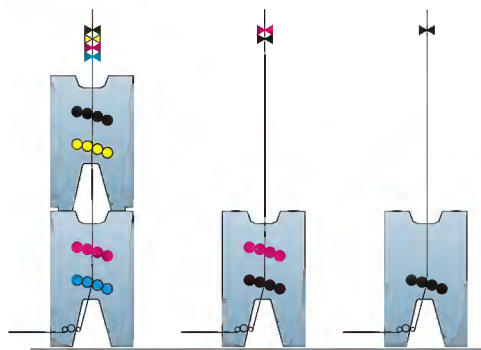

Wide variety of web leads to suit individual needs

Selecting your FRONTLINE : A world of possibilities

If color pagination is high, and back-to-back 4 color is a requirement, Tower configuration with its vertical web leads is the most ideal solution. Tower configuration of FRONTLINE is supported by reliable tension control system, short web paths and anti fan out devices ensuring perfect register. The H-H configuration delivers 4 color printing on each side with single web. Alternatively, 3 webs also can be passed for printing single color.

A single H module could either be used for printing 2 webs with black-only back to back, or a single web with 2 colors back to back.

But the best thing about the FRONTLINE, as with all Manugraph products, is the ability to configure the different printing modules in a single pressline to best suit the specific requirements and space availability.

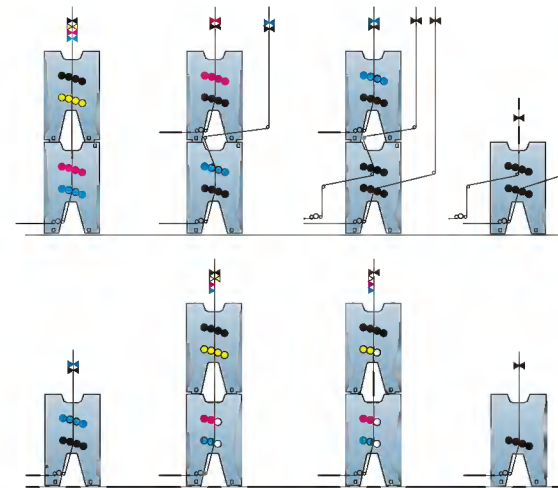

Combination of different module types for high flexibility

Choose the right configuration for the job

A modular four-page concept for press extension flexibility.

FRONTLINE provides a wide range of production variants. One of the outstanding features of FRONTLINE is that the pressline can be extended in the future to suit your requirements.

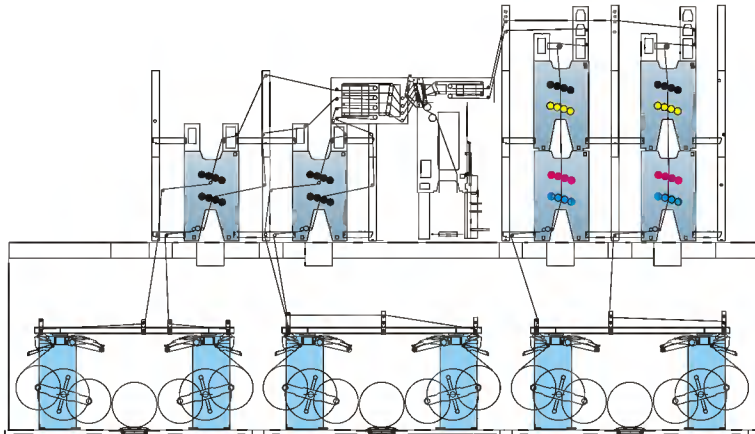

Vertical web lead configuration with reel splicer at basement.

MAXIMUM PRODUCTION - 24 PAGES.

- 8 pages in 4/4 colour.
- 16 pages in 1/1 colour.



Vertical web lead configuration with reel splicer at basement.

MAXIMUM PRODUCTION - 24 PAGES.

- All pages in 4/4 colour.

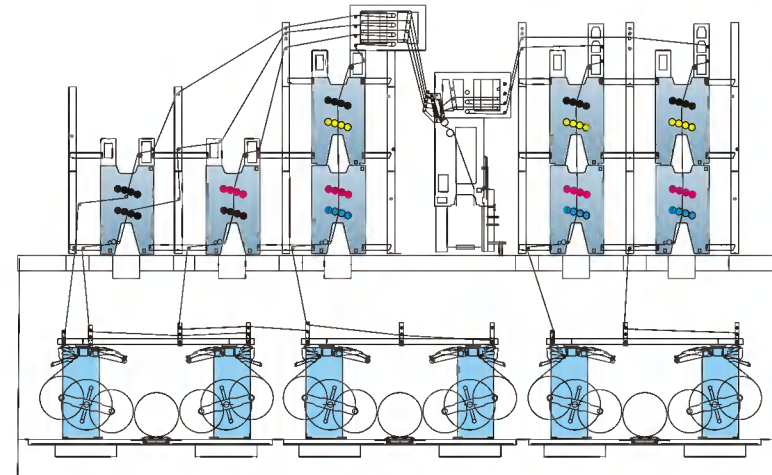

Vertical web lead configuration with reel splicer at basement.

Position of colour web can be changed by using bay window.

MAXIMUM PRODUCTION - 24 PAGES.

- 12 pages in 4/4 colour.
- 8 pages in 1/1 colour.
- 4 pages in 2/2 colour.

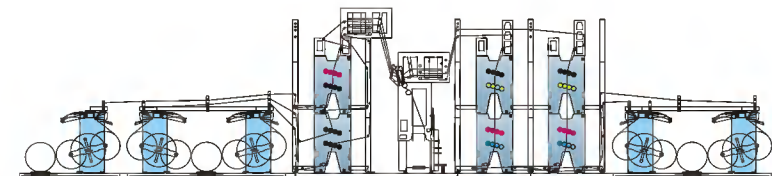

Vertical web lead configuration with inline reel splicer.

MAXIMUM PRODUCTION - 20 PAGES.

- 8 pages in 4/4 colour.
- 8 pages in 1/1 colour.
- 4 pages in 2/2 colour.

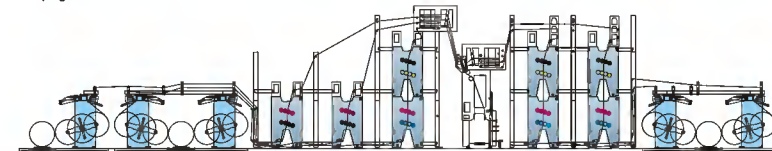

Vertical web lead configuration with inline reel splicer.

Position of colour web can be changed by using bay window.

MAXIMUM PRODUCTION - 20 PAGES.

- 12 pages in 4/4 colour.
- 8 pages in 2/2 colour.

Plate and Blanket Cylinders for top performance

The dynamically balanced plate and blanket cylinders are made of stainless steel and mounted on three race bearings. The blanket cylinders are corrosion-protected by a special surface coating. All cylinders have bearer rings made of tool steel on either side. Automatic lubrication system is provided for bearers.

Plate cylinders have a narrow slot toolless plate lock up system, and blanket cylinders have spindle-based blanket clamping system for quick mounting of blankets. The plate lock up design facilitates fast and easy plate changes. Register wedges provided in the cylinders ensures quick plate lock up in true register. Adjustment to circumferential and lateral register is motorized.

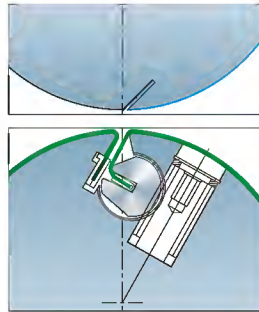

Main Feature : Three-race roller bearings

A constant printing quality over the entire speed range is ensured on the FRONTLINE press, thanks to the play-free three-race roller bearings used on the FRONTLINE press.

The middle eccentric ring serves for the cylinder throw-on/-off motion via an eccentric adaptor ring. The inner race of the bearing ensures the rotational motion of the cylinder. This newly developed bearing technology makes sure that the forces released by the blanket cylinder slot upon impression are optimally transmitted to the side frames and thereon to the ground.



Shaftless Drive Technology

FRONTLINE has a shaftless drive system which ensures minimum make ready time. Each H unit has its own AC servo-motor and drive control. All motors are electronically synchronized. Drive and electronic components are housed in separate control panels. The drive gears are hardened and ground very precisely to ensure smooth running and increased life of the press. The lubrication system is continuous for gears through separate motor at drive side.

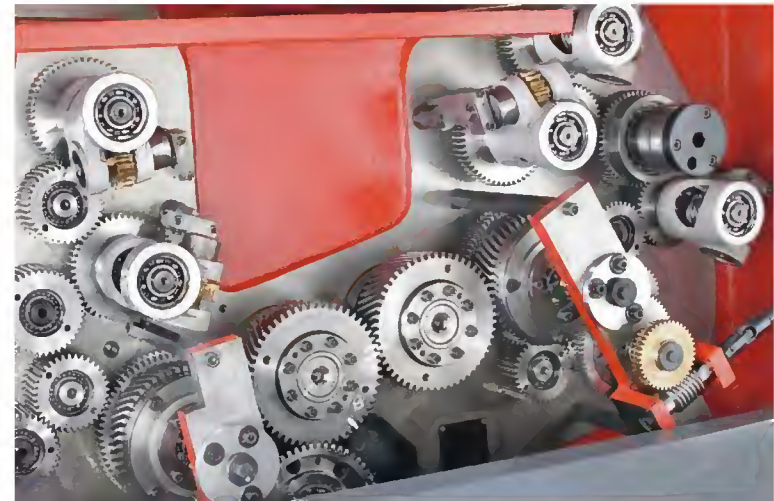

The Inking System & ManuColor : Remote inking, Ink Pre-setting

The film inking system consists of a 9-roller ink train with 2 forme rollers of different diameters and two Rilsan coated oscillating distributors.

The ink duct is of generous capacity and has an undershot blade with 22 ink keys for fine regulation of ink across the web width. The sturdy, anti-torsion ink fountain provides reproducible setting of the ink blade and ensures a uniform ink metering. The rigid ink fountain roller is supported on high-precision bearings. The ink blade is of drop down type and the entire fountain assembly can be swung away for ease of cleaning and maintenance. The entire system is of a solid, wear-resisting type designed for maximum print quality, fast change of ink and low maintenance.

A separate DC motor having auto-tracking facility with the press speed as programmed by the operator, drives the ink duct roller. The speed of the ink duct roller can be varied from the central console and also from the individual print units.

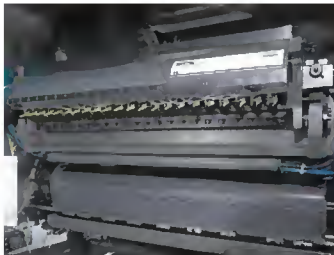

ManuColor is a standard feature of FRONTLINE and is CIP3 compatible for ink key presetting. The ink keys can be remotely controlled from the central console of ManuColor. Alternatively, remote Ink Control Systems from 3rd party auxiliary suppliers can be incorporated.

As the ink blade is of the segmented type, most accurate zonal control of ink is ensured.

Each inking unit is equipped with a roller wash-up device. The ink fountains of FRONTLINE can optionally be equipped with ink pumps and an automatic ink level sensing and regulation system for automatic ink supply.

And, optionally, the Rilsan coated oscillating distributor may be water-cooled.

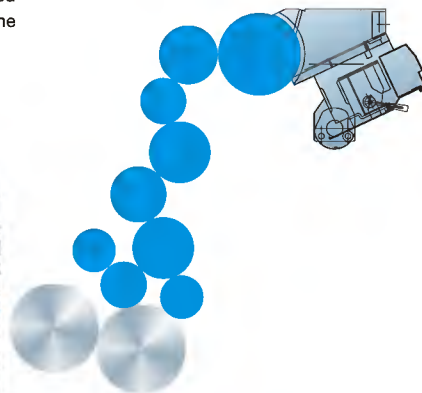

Contactless Spray Dampening System

Spray Dampening :

Lateral Shutters :

For webs of different widths, lateral shutters can be used in pairs. Both shutters are adjusted symmetrically from a central point of operation to limit the outer spray angle. Precise adjustments of the shutter position is supported by a scale.

The system offers wide range of functions :

- Automatic and manual over-dampening
- Storage of individual dampening solution curves per printing unit
- Individual nozzle adjusted
- Password protection to protect sensitive functions
- Detailed presentation of operating parameters, status and fault messages

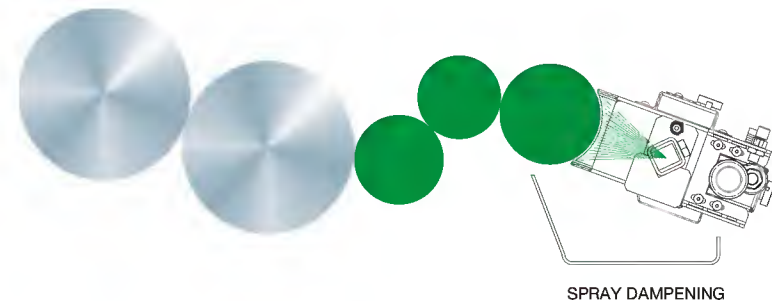

Folder : Robust Construction, Modular Design, Reliable

Folder components, product versatility

FRONTLINE folder is designed to meet the requirements of Newspaper production. It guarantees reliable operation at all speed ranges.

The folding module and RTF roller are driven by an AC Servo motor shaftless drive. These motors are controlled from central control console for perfect web tension.

The basic 2:3:2 pin/jaw type folder can be combined with additional folders for 3rd fold (2nd longitudinal fold) and/or parallel fold (2nd crossfold) in a modular system. Facilities for gluing, stitching and perforation are available.

The circumference of the folding cylinder corresponds to a triple cut-off length. This

Fast changeover-reliable operation

Folders and functions

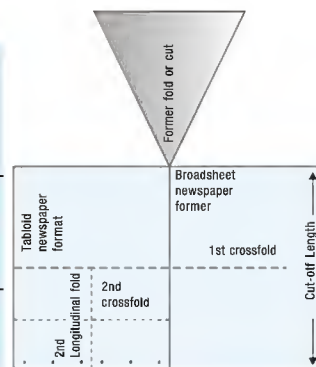
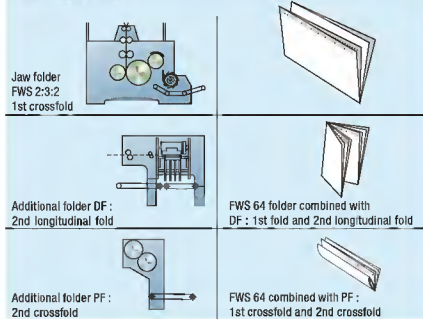

Web reversing, turning and positioning

In order to feed the paper webs into the folder formers in the required position, air-skirted turner-bar facilities in the form of parallel and pony turning bars as well as bay-window turning devices are provided.

Custom-designed former superstructures

FRONTLINE is equipped with air-skirted 70° formers, shaftless AC motor driven RTF & collecting roller. However, Balloon formers allow production of multi-section newspapers in broadsheet format. The Balloon former roller is driven by a separate AC Servo drive motor.

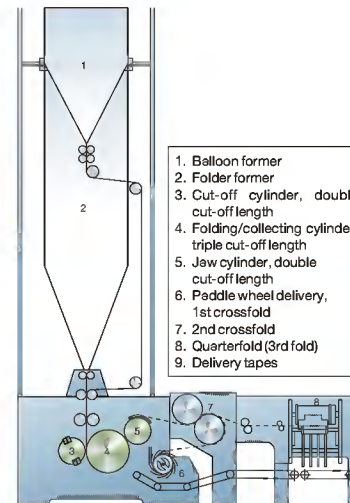

Safety devices of the folder

The folder has two safety devices for the prevention of paper jams. The first device is a web severer arranged at the folder infeed, which sever the paper feed into the cylinder group and avoids further damages. The paper web still running until the press stops is guided out of the folder. The second device is an AC synchronised overload protected shaftless motor arranged in the folder drive, which additionally safeguards the cylinder group.

Features

- 2:3:2 rigid jaw folder
- Separate AC Servo drive motor for RTF
- Air cushioned 70° former
- One or two upper formers for 2 or 3 section products
- Lap adjustment facility, on-the-run
- Folding cylinder with diameter increment facility
- Slitter mechanism for tabloid production
- Web severer in the folder
- Electronic multi sheet detection facility and adjustable batch counter
- Optional attachments:
 - ▲ Rotary 3rd (quarter) fold
 - ▲ Double parallel fold
 - ▲ Longitudinal and cross perforation
 - ▲ Facilities for gluing & stitching
 - ▲ Motorized cut off control

Perfect Web Control from reel stand to folder

Web travel

Manugraph web control system guarantees uniform and precise tension in the pressline. This starts from reel splicer where closed loop tension control is achieved through pneumatically operated dancer coupled with an effective braking system. Next, there is an integrated infeed unit prior to web entering the cylinder nip which can be controlled from the central console. This infeed unit has a variable drive steel roller and a pneumatically operated pressing roller.

Especially in multi-colour printing, the infeed unit is an important facility for ensuring

uninterrupted, true-to-register production. On the exit of the tower, there is an inertia roller and further up, the web tension is controlled by AC Servo Motor driven draw rollers located in the folder superstructure. The speed of these rollers is controlled from the central console. Finally, the RTF has its own controls to ensure perfect tension before the web enters the former. Then, the folder module also has a separate AC Servo motor drive. This total control over the web throughout the press from reel stand to folder, results in outstanding printing quality, low wastage and high level of operational reliability.



Reel splicers of solid and reliable design

The reel splicer provides reliable automatic reel change at any web speed. The reel splicer is provided with an electro-pneumatic control system including a central braking facility.

The reel splicer is further equipped with automatically re-tensioning lock-up cones for reel loading and is characterized by its lean and space saving design. It splices at upto 10.5 m/s and can handle a maximum reel weight of 1200 kg, making it also suitable for higher-grade newsprint.



Features

- Can be placed in-line, or at right angles, or at the basement
- Compact space saving design
- Two full reels can be handled at a time
- Pneumatically operated core holding lock-up
- Motorized lateral adjustment from central as well as local control panel
- Easy reel loading
- Reel acceleration by belt and thyristor controlled drive. Pasting is initiated after synchronizing the web speed. Hence, 99% pasting performance is guaranteed

Total Press Control

Central Console & PLC

The Central Console has operating switches for all press drive functions, and a color touch screen operator interface from where all print units can be accessed and functions controlled, in both auto and manual mode. Functions such as dampener & inking roller speed adjustment and pre-programmed ink and water balance settings can be easily achieved from the touch screen. Basic data such as machine speed, gross copy, net copy, stack functional status are all displayed on the touch screen.

For the tower units, motorized registration, bustle wheel adjustment and cut-off register roller adjustment are remotely controlled from the touch screen. Fault diagnostics and periodic maintenance guidelines are also displayed.

ManuColor, the Remote Ink Control System from Manugraph is also integrated into the control console. Alternatively, Remote Ink Control Systems from standard third party auxiliary suppliers can be incorporated.

Electricals

Press controls

Basic level module



Manugraph Press Control

Press Control	Central Console	Print Unit Controls	Options
Machine Controls	<p>Color Touch Screen Console for Central Press Control</p> <ul style="list-style-type: none"> • Direct access to any print unit and related print functions, in auto or manual mode • Auto tracking of inking & spray opening according to selected pre-programmed curves • Facility for feeding new ink/water balance curves to suit for specific job • Copy counter for Net/Gross copies • Batch selection • Central fault/alarm message • Maintenance scheduling • Web break selection access • PLC based structure • CE Certification • Machine drive related commands 	<p>Print Unit Panel with Touch screen for Local Control</p> <ul style="list-style-type: none"> • ON/OFF control for Impression, Dampening, Inking & Film rollers • Water & ink balance film override curve facility • Web break selection ON/OFF facility • Fault/Alarm display in Text for particular unit • Manual Registration adjustment • Manual ink zone control • PLC's for individual units connected to Console PLC on high-speed network • Fault messages, function status • Motorized cut off control • Lateral reel shifting • Webbing up control • Plate positioning control • Local mode control for shaft-less motors 	
Registration Controls	<p>Remote control of motorized registration (Close Loop)</p>	<ul style="list-style-type: none"> • Registration adjustment 	<ul style="list-style-type: none"> • Integration of close loop cut-off control and remote registration system from 3rd party suppliers
Ink Control	<p>Remote control of ink zones with CIP3 compatibility</p> <ul style="list-style-type: none"> • Separate 15" colour touch screen for Remote ink zone • Segmented blade • Job storage • 41 mm zone width • 3 micron min. step • Multi movement of motors • Manual override • Manual calibration • Self diagnostics • Individual/all zone increase/decrease • Locking of control keys • Job saving/pre-setting • Change of colour order • Editing notes • Date & time • CE Certification 	<ul style="list-style-type: none"> • Motorised Ink Screws with Controller • Lever for manual override 	<ul style="list-style-type: none"> • CIP3 interface